



Tech·Solution

Part of **Granly Diesel**



Marvel TS100 Micro asphalt paver

Manual

Read this manual carefully and understand the contents before operating the machine.



If the manual is lost or damaged,
a new one can be ordered from
Tech - Solution.

Manual version TS-01

MARVEL TS-100

1. EU Declaration of Conformity.....	3	8. Asphalt materiale hopper.....	16
2. Foreword.....	3	8.1 - Asphalt materiale hopper and auger.....	16
3. Preface.....	3	- Maintenance	17
4. legend of symbols.....	4	- Check engine oil level	
5. Machine introduction.....	5	- Check hydraulic oil level	
5.1 Intended use.....	5	- Check coolant level	
6. Safety informtion.....	5	- Clean air filter	
6.1 Safety.....	6	- Lubricate moving parts	
6.1.1 General safety precautions.....	7	- Clean radiator grille	
6.1.2 Personal protective equipment.....	7	10. Service interval.....	22
6.1.3 Dangerous situations.....	7	10.1 Replacement of engine oil and oil filter.	23
6.1.4 Safey zone	7	10.2 Check and adjust fan belt.....	23
6.1.5 Seat and contact.....	7	10.3 Replacement of diesel filters.....	23
7. Operating instructions.....	8	10.4 Replacement of hydraulic filter.....	24
7.1 Instrumentation manual.....	8	10.5 Adjustment of chain for laying tool.....	24
7.2 Operation of instrumentation equipment.	10	10.6 Replacement of hydraulic oil.....	24
7.2.1 Throttle handle.....	10	10.7 Replacement of coolant.....	24
7.2.2 Accelerator pedal.....	10	11. Troubleshooting.....	25
7.2.3 Engine temperature.....	11	11.1 Towing.....	25
7.2.4 Fuel gauge.....	11	11.2 Troubleshooting chart.....	26
7.2.5 Hour meter.....	11	12. Technical Data / Specifications.....	27
7.2.6 Ignition.....	12	12.1 Technical specifications.....	27
7.2.7 Asphalt dosing pedal.....	12	12.2 Noise level.....	27
7.2.8 Asphalt dosing adjustment.....	12	13. Hydraulic diagram.....	28
7.2.10 Battery.....	13	14. Electrical diagram.....	29
7.2.11 Float pressure gauges.....	13	15. Warranty conditions.....	34
7.2.12 Hydraulic control panel.....	13	16. Additional equipment.....	36
7.3 Control during operation/driving.....	14	Central lubrication - SB5.....	39
7.3.1 Cooling system control and operation.	14	17. Service manual.....	49
7.3.2 Oil indicator control and operation....	15		
7.3.3 Leak check.....	15		

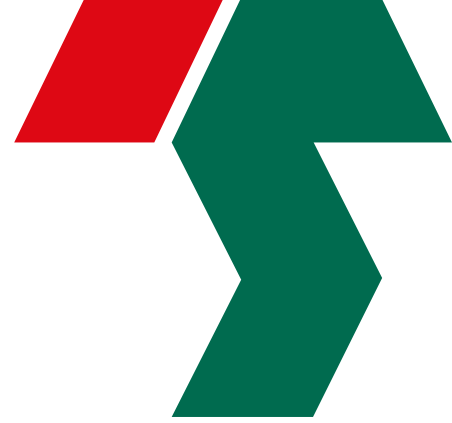

2. RIGHTS

This user manual is published by Tech-Solution, which holds all rights. The document or parts thereof may not be reproduced, copied, or distributed electronically or in paper format without written permission from Tech-Solution.

Tech-Solution reserves the right to continuously update the user manual and documents to reflect the current version of the product and is not obligated to update already distributed copies.

Tech-Solution will, therefore, inform users of significant changes to user manuals or documents on the company's website.

3. Foreword

Congratulations on Your New Marvel TS100

This User Manual has been prepared for the use of the Micro Asphalt Paver Marvel TS100. The user manual is an important part of your new asphalt paver and should be thoroughly read before operating the machine. If you have any questions about the use of the machine, you are always welcome to contact Tech-Solution via the service phone for information. However, please note that the manual can be used as a reference guide for troubleshooting, spare parts, and usage instructions.

The user manual for this machine contains important information about safety and operation.

Therefore, the user manual should be kept with the machine.

The manual should also accompany the machine in the event of resale or loan.

The person responsible for the work must ensure that the operator, service personnel, and others who have access to the machine's operation are instructed on the correct use and handling of the machine. The owner/user of the machine is responsible for ensuring that the person in charge of the work is informed of this.

Remember, Tech-Solution places emphasis on user safety and recommends job rotation.

Should you have any questions about the machine or its use, you are always welcome to contact Tech-Solution via the service phone for information. Please refer to this user manual for further information on usage and troubleshooting.

4. LEGEND OF SYMBOLS

The user manual is structured with symbol explanations. These symbols highlight important instructions that should be read before using the machine. The symbols used have the following meaning!



NOTE!

A triangle containing an exclamation mark is a warning symbol that alerts you to important instructions or information regarding this machine.



IMPORTANT INSTRUCTION!

A reminder that the section contains particularly important information for the operator.



DANGER!

A triangle containing a warning about the risk of personal injury and crushing hazard on this machine.



HEARING PROTECTION!

Hearing protection required! Operators and other individuals within the machine's working area must wear hearing protection.



ELECTRICAL SHOCK!

A triangle containing a warning about the risk of electrical shock.



SAFETY FOOTWEAR!

Tech-Solution recommends that all individuals within the machine's working area wear safety footwear.



EXPLOSION HAZARD!

A triangle containing a warning about the risk of explosion.



GLOVES!

Tech-Solution recommends that all operators wear gloves.



BURN HAZARD!

A triangle containing a heated thermometer, supplemented with a warning triangle about the risk of burn hazards.



SAFETY GLASSES!

Tech-Solution recommends that service technicians wear safety glasses when performing service work on the machine.



CORROSION HAZARD!

An inverted triangle containing a warning about the risk of corrosion hazard.



EYE CONTACT!

Use eye wash immediately upon contact with the eyes to reduce the risk of irritation or damage. If discomfort persists or irritation does not go away, seek medical attention.

5. MACHINE INTRODUCTION

5.1 - INTENDED USE

Tech-Solution Micro Asphalt Paver is constructed and designed for the laying of asphalt.

• **The asphalt paver must not be used for any purpose other than what the machine is designed for.**

In the design and construction of the machine, primary consideration has been given to the safety of the operator and the surrounding work environment. This includes the machine's structural design, proper setup, and its maintenance.

NOTE!

The person responsible for the work must ensure that the operator, service personnel, and others who have access to the machine are instructed on the correct use and handling of the machine. Refer to this user manual for further information.

The entire user manual must be read thoroughly before the machine is used.

The machine may only be used for the purpose for which it is designed. Any other use will invalidate the legal responsibility according to the CE marking's declaration of conformity.

Regardless of any issues that may arise with the machine or operation, no faults should be corrected until the machine is safely turned off, unless the correction can be made using the machine's operating controls.

The operating manual should always be kept accessible for the operator.

If the machine is used by young persons over the age of 16, it is not a requirement for the young person to have a tractor driver's license according to the Danish Working Environment Authority's notice No. 239, Annex 2, Section 2, Item C.

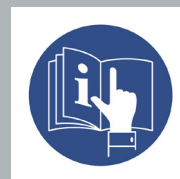

6. SAFETY INFORMATION

The user manual should always be read before using the machine. This is to ensure that the operator gains the optimal safety and information for operation, as well as to ensure the machine's safety to prevent accidents.

NOTE!

It is the legal obligation of the person responsible for the work to instruct all users on safety measures.





6.1 - SAFETY

6.1.1 - GENERAL SAFETY MEASURES

It is the legal obligation of the person responsible for the execution of the work to instruct all users.

- Know your machine and its limitations. This user manual should be read thoroughly before starting and operating the machine.
- Before allowing others to use the machine, you should thoroughly explain how it should be handled and have them read this user manual carefully.
- For safety reasons, inexperienced personnel should test the machine in an open and flat area, at low engine speeds, to get accustomed to the machine's propulsion system.
- The engine's exhaust gases are very harmful if allowed to accumulate. If the machine is parked with the engine running, it should be placed in a well-ventilated area, away from people and animals.
- Be cautious for environmental and ecological reasons.
- Before draining any liquid, make sure to dispose it correctly. Follow relevant environmental protection regulations when disposing of oil, fuel, coolant, filters, and batteries.
- Never remove the radiator cap while the engine is running or after it has stopped if the engine is still hot. This poses a burn hazard to individuals nearby. Wait until the engine has cooled before removing the radiator cap. This can take 10 to 20 minutes, depending on the climate.
- Always use high-quality parts and accessories when replacements are necessary.
- Release any pressure in the oil and cooling systems before removing or disconnecting hoses, brackets, or similar components. Never check for leaks with your hands, as high oil, water, or fuel pressure can cause personal injury.
- Always ensure that the coolant and oil drain valves are closed, that the radiator cap is securely closed, and that the hose clamps are tightened before starting. If any of these parts are removed or loose, the engine should not be started. This can result in serious personal injury.
- Do not mix gasoline or alcohol with diesel fuel, as this can cause an explosion.
- Never operate the machine in environments where there is, or could be, a risk of flammable substances or fumes.
- Always stop the engine during daily or periodic maintenance, refueling, inspections, or cleaning.
- Operators and other individuals within the machine's working area must wear hearing protection, as the machine's noise level exceeds 80 dB.

6.1.2 - PERSONAL PROTECTIVE EQUIPMENT

Tech-Solution prioritizes safety and recommends using personal protective equipment. See fig. 6.1.2.1.

6.1.2.1 - Hearing protection is required during normal use. Tech-Solution recommends wearing safety footwear and gloves. For repair and maintenance, Tech-Solution also recommends wearing safety glasses.



Hearing Protection Required



Safety footwear is recommended for everyone



Gloves are recommended for everyone



Safety glasses are recommended for service technicians

6.1.3 - DANGEROUS SITUATIONS

NOTE!

Avoid sudden shifts between forward and reverse, as this can cause the machine to tip over.



DANGER!

Stay in the materiale hopper or perform maintenance on the machine, repairs, cleaning, and other servicing must not begin until the engine has been stopped.



DANGER!

To avoid injuries to individuals: The machine must be stopped, the engine turned off, and set to position P during the repair of the augers or their components. When rotating, there is a risk that fingers/hands could get caught.



DANGER!

To avoid injuries to individuals: The machine must be stopped, the engine turned off, and set to position P during any adjustment of the tools.



6.1.4 - SAFETY ZONE

When the machine is operating, stay outside the safety zone, which is 50 cm all around the machine.

6.1.5 - SEAT BELT AND SEAT CONTACT

The machine's seat is equipped with a seatbelt and a seat contact, so the machine cannot operate if the operator is not seated.

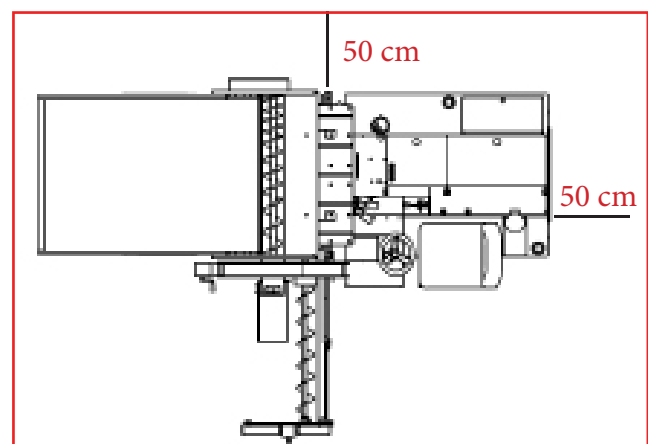

7. OPERATING INFORMATION

The asphalt paver is equipped with an instrument panel from which the machine's functions are controlled and monitored, both before startup and during operation. For correct use and control of the machine before startup and during operation, this section must be read before starting and using the machine.

7.1 - INSTRUMENTATION GUIDELINES

Fig. 7.1.1 Shows a standard-built Micro Asphalt Paver.

1. Foot pedal for asphalt dosing

2. Steering wheel and steering knob

3. Throttle

4. Control panel
See below.

5. Engine temperature
Control for engine warm-up.

6. Fuel gauge

7. Hour meter

8. Ignition
Engine pre-heating + start.

10. Drift pedal
Forward or reverse movement of the machine.

11. Asphalt dosing adjustment
Auger 1 - Box
Auger 2 - Tool

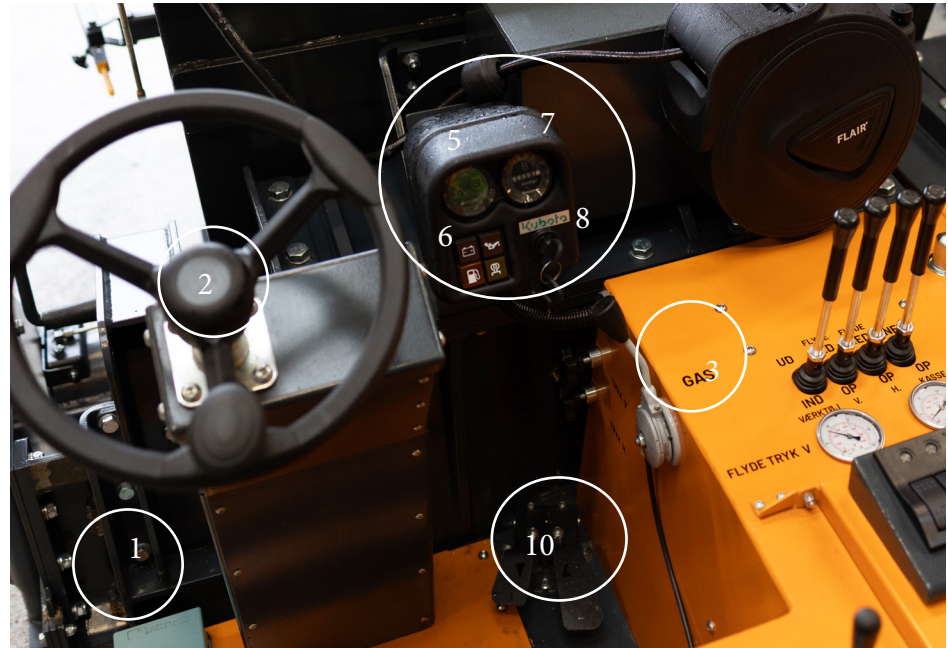

- | |
|---|
| <p>4. Control panel
1 - Lights
2 - Foot pedal auger 1
3 - Available
4 - Vibrator (*Accessory)
5 - Additional work lights (*Accessory)
6 - Horn</p> |
|---|

13. PREHEATER INDICATOR LIGHT

The symbol lights up during engine preheating. When the symbol turns off, the engine is ready to start.

If there is no light in the symbol during engine preheating, this is a warning. **STOP!**

14. BATTERY / CHARGING LIGHT

The symbol lights up red during ignition for a functional check. The symbol should be off during operation. If the symbol lights up while operating, this is a warning. **STOP!**

15. OIL INDICATOR LIGHT

The symbol lights up red during ignition for a functional check. The symbol should be off during operation. If the symbol lights up while operating, this is a warning. **STOP!**

16. 12V / 53A Battery

17. Float pressure gauge

18. Control valve

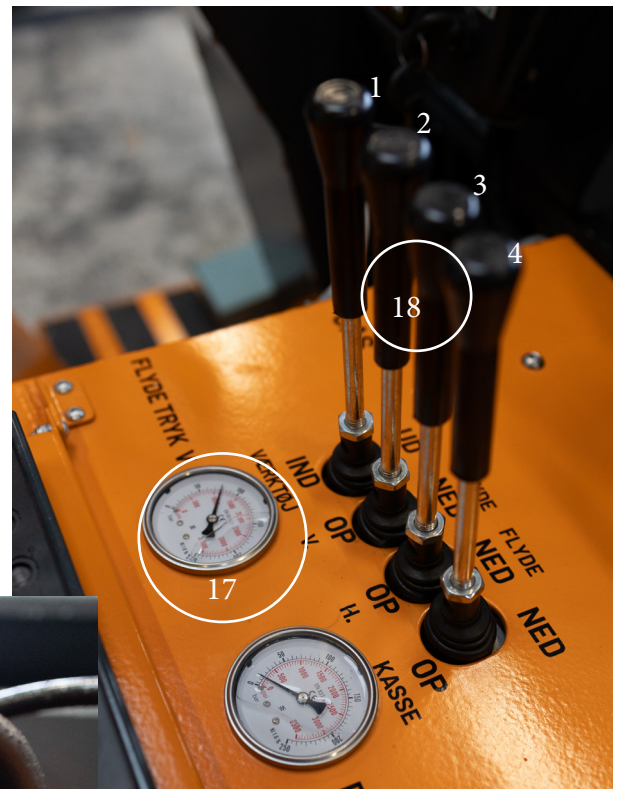

- 18. Control Valve**
- 1 - Tool in/out**
- 2 - Tool up/down float position**
- 3 - Tool right up/down float position**
- 4 - Box up/down**



7.2 - OPERATION OF INSTRUMENTATION EQUIPMENT

For correct guidance and instruction of the machine, each of the subgroups for the instrumentation manual is described.

7.2.1 - THROTTLE HANDLE

Pos.3. fig. 7.1.1:

The machine is equipped with a gas handle. Pulling it backward increases the engine RPM, resulting in higher speed for both the machine's movement and Auger 1 in the tool. Pushing the gas handle forward reduces the engine RPM. The gas handle is mechanically cable-operated and not spring-loaded, meaning it does not return to a neutral position without operator activation.

NOTE

The throttle lever is mechanically cable-controlled and does not return to the neutral position without the operator's activation.



NOTE

Avoid sudden shifts between forward and reverse at high engine RPM, as this can cause damage to the hydraulic system.



7.2.2 - DRIFT PEDAL

Pos.10. fig. 7.1.1:

The asphalt paver can drive both forwards and backwards. Pressing the drive pedal activates movement. For forward movement, the right pedal should be pressed. For reverse movement, the left pedal should be pressed. The drive pedal is part of the machine's hydraulic system. The speed is determined by the engine's RPM.

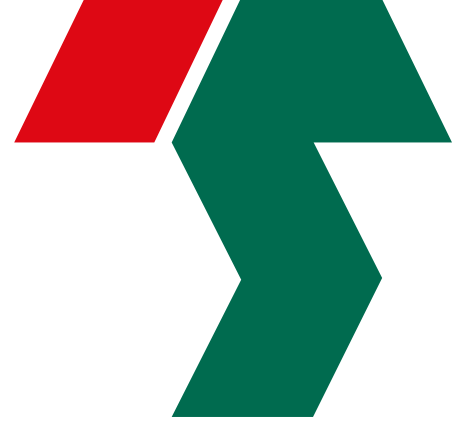

7.2.3 - ENGINE TEMPERATURE

Pos.5. fig. 7.1.1:

The instrument panel is equipped with an engine temperature gauge. The gauge informs the operator of the engine's operating temperature.

NOTE

If a warning appears on the control panel, the machine must be stopped immediately.



NOTE

- If the operating temperature exceeds 95°C, the engine must be stopped immediately.
- Continuing to operate with an excessively high temperature will damage the engine.



7.2.4 - FUEL GAUGE

Pos.6. fig. 7.1.1:

The instrument panel is equipped with a fuel gauge, which shows the amount of fuel in the fuel tank. The fuel gauge lights up when the ignition is turned on. Never run the machine out of fuel as this can clog filters and hoses. The light will turn on when the machine switches to the reserve tank.

7.2.5 - HOUR METER

Pos.7. fig. 7.1.1:

The instrument panel is equipped with an hour meter.

The hour meter indicates the total operating time in hours that the asphalt paver has been active. The hour meter is activated when the ignition is on and lights up on the instrumentation panel.

NOTE

The hour meter does not indicate any warning regarding service intervals. Therefore, the operator should remain mindful of the operating hours and service intervals.



7.2.6 - IGNITION

Pos.8. fig. 7.1.1:

The instrument panel is equipped with an ignition switch for activating the engine. The ignition switch has four functions. See fig.

1. DISCONNECTED

There is no ignition to the engine. The key can be removed from the switch.

2. IGNITION

By turning the key to the right, the ignition for the machine is activated. The control panel is activated, and functions light up.

3. PRE-HEATING

By turning the key to the right again, keep the key in position 3 until the pre-heating light goes off.

4. START

The key is turned to Position 4 to start the engine after warming up. When the key is released, it turns and stays in the ignition position 2 during operation.

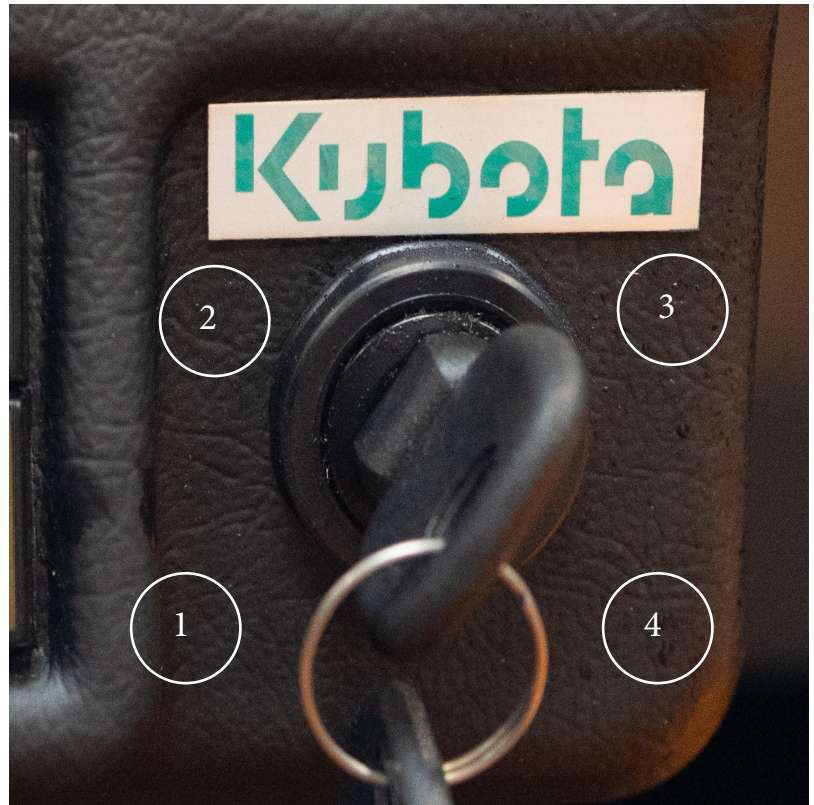

7.2.8 - ADJUSTMENT OF ASPHALT DOSING

Pos.11. fig. 7.1.1:

The machine is equipped with a dosage regulator that can control the amount of asphalt to be laid. The regulator is adjusted by turning it to the right or left, which then regulates the pump's rotation speed to control the asphalt supply quantity.

7.2.7 - ASPHALT DOSING PEDAL

Pos.1. fig. 7.1.1:

The machine is equipped with an electric asphalt dosage pedal on the left side of the machine. The asphalt dosage pedal is connected to the function switch, allowing the operator to control the amount of asphalt dispensed during operation. This setup provides precise control over the asphalt flow for consistent and efficient application.

pos. 1. Fig. 7.1.1.

When the electric asphalt dosage pedal is activated by foot contact, the auger is activated. The direction of rotation depends on the position of the function switch.

IMPORTANT

It is important that the engine always runs at the same RPM during laying, as varying RPM will result in different asphalt application amounts.



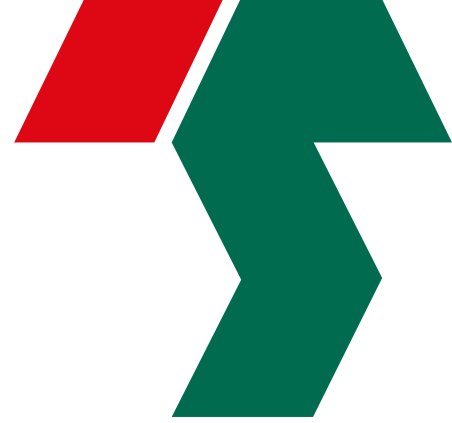

7.2.10 - BATTERI

Pos.16. fig. 7.1.1:

The battery is located in the tool compartment on the right side of the machine. It is originally installed with a 12V / 53A battery.

7.2.11 - FLOW PRESSURE GAUGES

Pos.17. fig. 7.1.1:

For displaying the tool's pressure on the asphalt, respectively for the right and left sides.

7.2.12 - CONTROL VALVES

Pos.18. fig. 7.1.1:

From the left, when sitting on the machine:

Handle 1 - Tool in/out

Handle 2 - Tool up/down left side

Handle 3 - Tool up/down right side

Handle 4 - Box up/down

Handles 2 and 3 are pushed forward to the 2nd position to enter the float position.

IMPORTANT

- If the oil light does not turn off immediately after starting the engine, the engine must be stopped immediately.
- The engine must be brought to normal operating function before activation/start again.
- If there is no control light during ignition, the machine must not be activated/started.
- The control panel must be brought to normal operating function before activation/start.
- If the engine does not start within 10–20 seconds after activation, wait approximately 30 seconds before attempting activation again.
- When attempting to start the engine again, follow the instructions again.
- Before starting/activating the machine, a daily service must be performed. See instructions on page 17.



7.3 - CONTROL UNDER OPERATION / DRIVING

It is the operator's responsibility to ensure that the machine is used under the correct operating condition, which means continuous monitoring/inspection of the paver during operation.

The ongoing monitoring during the machine's operating condition is carried out through the machine's lights, the control panel's indicator lights, and the machine's service lights. See page 9.

7.3.1 - CONTROL AND OPERATION OF THE COOLING SYSTEM DURING OPERATION

During the operation of the machine, it is important to monitor the machine's operating temperature through the temperature gauge on the control panel.

If the machine exceeds its normal allowable operating temperature of max. 95°, the engine must be stopped immediately.

If the machine/cooling water starts to boil, steam, or water flows out through the overflow hose, the engine must be stopped immediately.

DANGER

To avoid personal injury:

Never remove the radiator cap while the engine is running, after it has been stopped, or while the engine is still hot. There is a risk that boiling coolant may splash from the radiator and scald nearby individuals.

The radiator cap must not be removed until the engine has been stopped and is cold.



NOTE

If a failure occurs in the engine's cooling system, the engine must be stopped immediately. The engine must be restored to normal operating condition before activation/startup.

Operating with a defective cooling system will result in damage to the engine.



7.3.2 - CONTROL AND OPERATION OF THE OIL INDICATOR DURING OPERATION

During the operation of the machine, it is important to monitor the machine's oil indicator via the control panel. If the oil light on the control panel illuminates, the engine must be stopped immediately.

If the engine oil pressure drops below the level specified by the manufacturer, the oil indicator will activate.

If the oil indicator lights up intermittently during operation, the engine must be stopped immediately.

NOTE

- If the oil indicator light illuminates, the engine must be stopped immediately. The engine must be restored to normal operating condition before activation/startup.
- Operating with a defective lubrication system or lack of oil will result in damage to the machine's engine.



NOTE

- Only the fuel quality prescribed by the engine manufacturer may be used:
- Diesel Fuel No. 2-0 (ASTM 0975).
- The person responsible for performing the work is accountable for using the correct fuel.



7.3.3 - LEAKAGE CHECK

Before each startup, the machine must be visually inspected for leaks:

- Fuel system
- Hydraulic system
- Cooling system
- Water tank

Tanks, visible pipes, and hoses should be checked for leaking or dripping fluid. The ground where the machine is parked should be inspected for fluid accumulations. If leaks are observed in any of the above, the machine must be assessed by a qualified person before it may be started. If necessary, contact Tech-Solution.

8. MATERIALE HOPPER

The asphalt materiale hopper is designed in such a way that it can be tilted up and down hydraulically, which allows for cleaning of the tank to be carried out without major obstacles.

NOTE

- The asphalt materiale hopper must never be tilted for cleaning during operation. Warning! It is forbidden and poses a great risk of finger and hand crushing due to the rotating auger.



8.1 - ASPHALT MATERIALE HOPPER AND AUGER

The asphalt hopper is equipped with an auger, which lays down the asphalt.

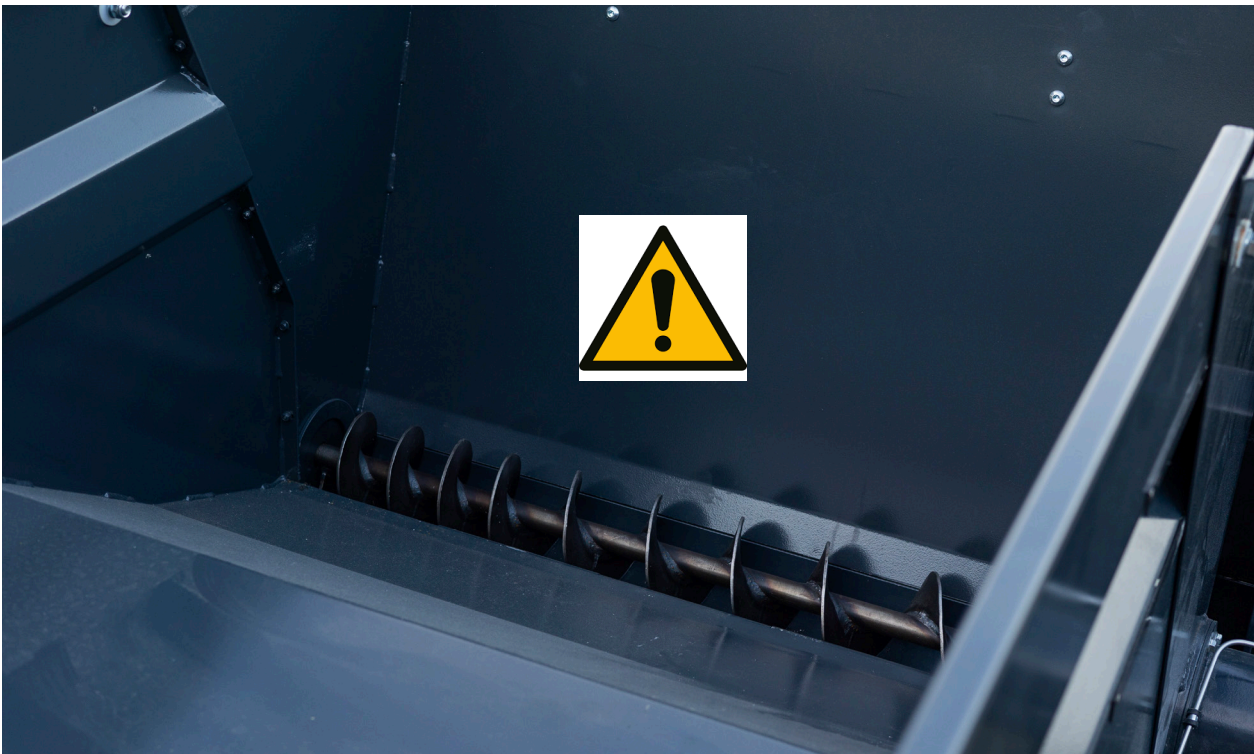

9. MAINTENANCE

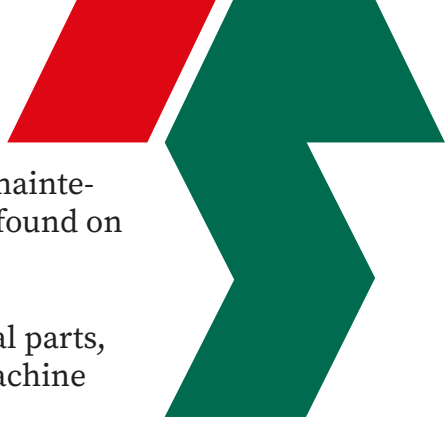

To ensure the best possible fault-free operation of the machine, a varied maintenance interval is necessary. The service schedule for the machine can be found on page 22.

- If no maintenance or repairs are carried out on the machine’s operational parts, or damaged parts from normal operation, all forms of warranty on the machine will be void.

Maintenance of the machine’s components is an important part of ensuring the machine’s operation, lifespan, and safety for the operator. Damaged parts or faults on the machine that are not addressed or repaired immediately can lead to malfunctions and damage to other components of the machine, which can cause personal injury.

DANGER

Maintenance, service, or repairs to the machine must be carried out immediately to ensure the operator’s safety and the machine’s operational reliability. Faults should be corrected to restore normal operational function before activation/startup.



Warning! Always stop the engine before beginning maintenance, cleaning, or any other form of service on the machine.

DAILY SERVICE

Check the engine oil level.....	18
Check the oil light.....	9
Check the charging light.	9
Check the hydraulic oil level.....	19
Check the coolant level.....	18
Check for leaks.....	15
Central lubrication check. If the light is red , there is a fault, and work with the machine stops. On page 43, you will find the fault management overview. When the light flashes or is constantly green, the central lubrication is working.	43

WEEKLY SERVICE

Cleaning of the air filter.....	19
Lubrication of moving parts.....	20
Cleaning of radiator grille	21

NOTE

- Always stop the engine before starting maintenance, cleaning, or any other form of service on the machine.
- The engine’s operating condition, including leaks and oil level, must be checked daily before use.
- If the oil level is low, the engine must be restored to normal operating condition before activation/startup.
- Operating with defective, missing, or incorrect oil will cause damage to the machine’s internal engine components.
- Only use the engine oil quality specified by the manufacturer.



CHECKING THE ENGINE OIL LEVEL

Check the engine oil level daily before starting. The machine must be level when checking the oil level. Pull out the dipstick and wipe it clean. Then insert it back in, pull it out again, and read the level. The oil level should be between the minimum and maximum marks, and top up as needed.

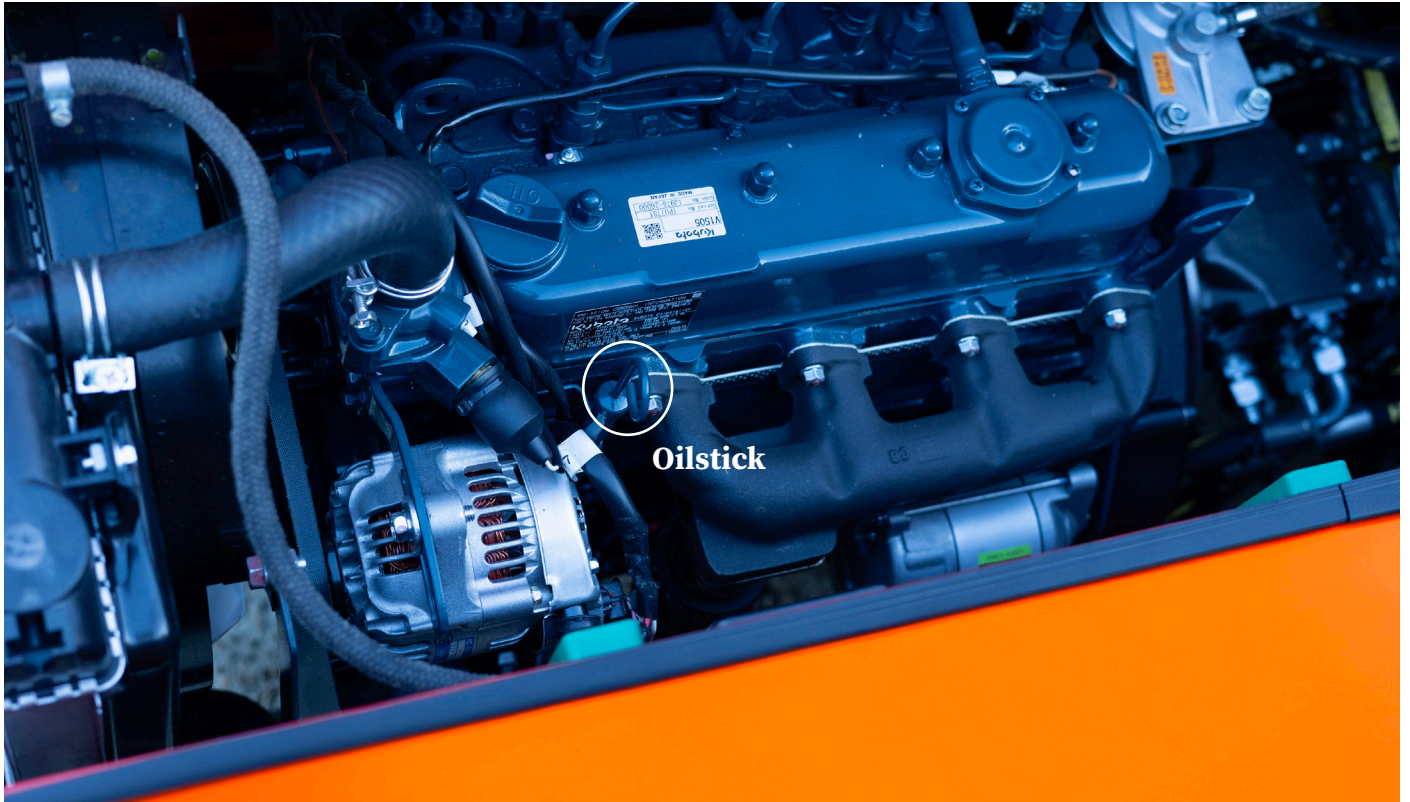

CHECKING THE COOLANT LEVEL

Remove the coolant cap after the engine has cooled down. Check that the coolant reaches the filling neck. Top up if necessary.

The Marvel TS100 is equipped with an expansion tank, which has “low” and “full” marks. The coolant level should be visibly between these two marks.



CHECKING THE HYDRAULIC OIL LEVEL

The hydraulic oil level is read on the upper part of the sight glass, on the right side of the machine.



Filling hydraulic oil.

MAX



CLEANING THE AIR FILTER

The air filter is cleaned with compressed air from the inside. If the filter is damaged, it must be replaced.





LUBRICATION OF MOVING PARTS

The paver is equipped with a total of 22 grease nipples.



Grease nipple

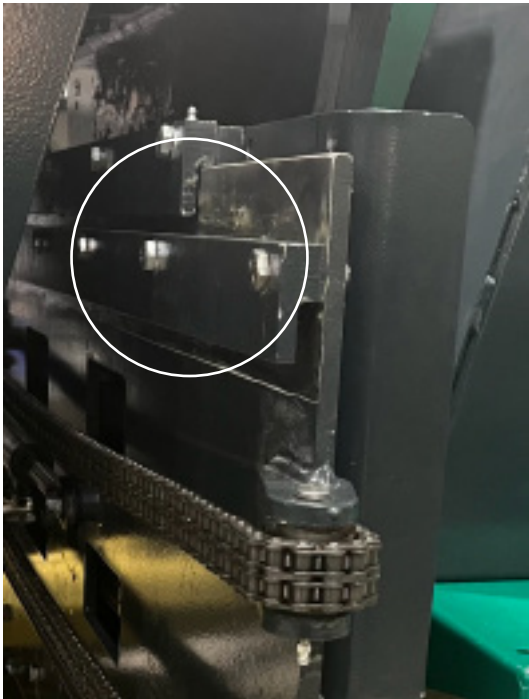

Grease nipple

Central Lubrication

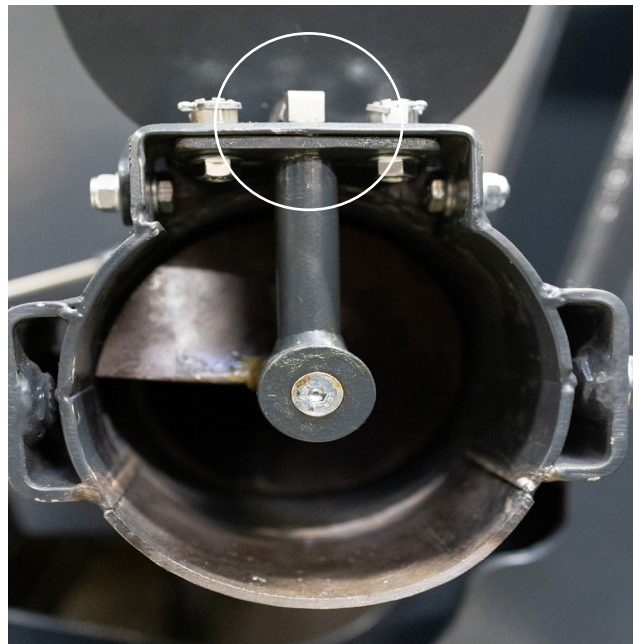

Grease nipple

CLEANING OF RADIATOR GRILL

The external cooling grille on the engine hood can easily be cleaned by hand. Do not spray bitumen near the cooler.



10. SERVICE INTERVAL

	After 50 Hours	Every 250 Hours	Every 500 Hours	Every 1000 Hours.
Change oil	X	X		
Change engine oil filter	X	X		
Clean air filter	X	X		
Check and adjust fan belt	X	X		
Change diesel filter			X	
Change diesel hose filter				
Change hydraulic suction filter			X	
Change hydraulic pressure filter			X	
Change hydraulic return filter			X	
Check and adjust chains for paving tools	X	X	X	
Top up hydraulic oil		X		
Change air filter		X		
Change fan belt			X	
Change hydraulic oil			X	
Change coolant				X

10.1 - REPLACEMENT OF ENGINE OIL AND OIL FILTER.

It is recommended that Tech-Solution performs this service task.

ENGINE OIL

Loosen the drain plug and drain the oil into an appropriate container. The engine holds approximately 4.9 liters of engine oil. Once the engine oil has been drained, screw the drain plug back in.

ENGINE FILTER

Clean around the filter and unscrew it. Screw on the new filter, remembering to lubricate the O-ring before attaching it. Now, pour in new engine oil until it reaches the top mark on the dipstick. Start the engine and check that the oil light turns off. Stop the engine after about 10 seconds, wait for approximately 30 seconds, and check the oil level. Top up the oil until it reaches the top mark on the dipstick again.

The engine oil must comply with the API-CD classification or higher.

10.2 - CHECK AND ADJUST THE FAN BELT

The fan belt is checked by applying a pressure of 10 kg in the middle of the belt. The fan belt should not deflect more than 7-9 mm. The belt is adjusted by loosening the top bolt, tilting the generator out, and then tightening the bolt again. Visually inspect the fan belt for cracks and visible wear. The fan belt should be replaced as needed or after 500 hours.

10.3 - REPLACEMENT OF FUEL FILTERS

The diesel hose filter is located at the diesel tank outlet. The diesel hose filter is positioned on the left side of the engine when viewed from the back of the machine. To replace it, loosen the two hose clamps and pull the hoses off the filter. Then, install the new filter in the reverse order.

The diesel filter is located at the front of the engine and is easily removed. Unscrew the old filter and screw on the new one, ensuring the O-ring on the filter is not dry when attaching it.

Bleeding is done by turning on the ignition, which activates the electric fuel pump to push diesel through the system.

To remove air from the filter, loosen the bolt at the top of the filter housing (using a 14mm wrench) until no air comes out and only diesel flows.



10.4 - REPLACEMENT OF HYDRAULIC FILTER

On the machine, there is a return filter with a filter indicator. It is located at the top of the machine on the right side. The return filter is a cartridge filter. Unscrew the cover and remove the old filter, then install the new filter and screw the cover back on.

10.5 - ADJUSTMENT OF CHAINS FOR LAYING TOOL

The chains are self-adjusting during daily use but must be adjusted during each service. Remove the cover on the right side of the machine, where each chain can be adjusted with two bolts. Set the chain so that it forms an almost straight line between the sprockets.

Lubricate the chain with chain oil before reattaching the cover.

10.6 - REPLACEMENT OF HYDRAULIC OIL

Either you can unscrew an oil hose at the bottom of the tank, or you can suction the oil through the fill port. The hydraulic tank holds 70 liters of hydraulic oil. Once the hydraulic oil has been drained, screw the hose back on. Now, pour in new hydraulic oil until it reaches the top of the sight glass. Start the engine briefly and stop it again.

Now, check the hydraulic oil level in the sight glass and top up as needed.

The hydraulic oil must be type ISO 46.

10.7 - REPLACEMENT OF COOLANT

Unscrew the two taps and drain the coolant into an appropriate container. One tap is located at the bottom of the radiator and the other on the left side of the engine. Once the coolant has been drained, screw the two taps back on.

Now, pour a mixture of water and coolant in a 50/50 ratio until the radiator is completely full.

Remember to check the level after the engine has reached operating temperature, allow the engine to cool down, and then check the level again. Top up if necessary.

The coolant must comply with SAE J 1034 or SAE J 1814c.

11. TROUBLESHOOTING

Tech-Solution has developed a troubleshooting chart in case of operational failures. (See page 26) The troubleshooting chart is for the operator to perform a quick diagnosis and is therefore less detailed. Major mechanical faults that require technical expertise should be handled by an authorized repair technician. If the issue is more complex than described, you are always welcome to contact Tech-Solution on the service phone for assistance.

11.1 - TOWING

If there is a need to tow the paver to a specific service workshop without its own engine power, it will be necessary to disengage the machine lock and loosen the BY PASS screw on the transmission pump, as it blocks the system.

INSTRUCTIONS FOR PROPER TOWING:

Before disassembling or servicing the machine's transmission system, the engine must be stopped and allowed to cool.



- Repairing the transmission system while the engine is running will cause damage to the transmission pump and wheel motors.
- Towing the paver before the BY PASS screw is loosened will cause damage to the transmission pump and wheel motors.

11.2 - TROUBLESHOOTING CHART

FAULT	POSSIBLE CAUSE
The engine will not start	Incorrect fuel. Air in the fuel pump. Empty fuel tank. Excessive piston clearance.
The engine starts but then stops again	Clogged air filter. Air in the fuel pump. Clogged fuel filter. Fault or blockage in the fuel supply. Blocked valve in the fuel tank. Burnt-out exhaust valve.
The engine has no power	Clogged air filter. Clogged fuel filter. Worn cylinder. Worn piston rings. Fault or blockage in the fuel supply. Burnt-out exhaust valve.
The engine has low oil pressure	Clogged lubrication circuit. Worn oil pump. Faulty oil pressure valve. Defective main bearings.
The engine is seized	Main bearings are seized or defective. Pistons are seized. Hydraulic pump blocked.
The engine is emitting blue smoke (diesel)	Worn valve guides. Worn cylinder. Too much oil in the crankcase. Worn piston
The engine is emitting black smoke (diesel)	Overload - Injection fault.
The engine is knocking in the crankcase	Small or large end bearings are seized or defective.
The engine is knocking in the rocker arm	Incorrect fuel. Too little piston clearance. Incorrect injection timing (diesel). Worn piston rings.
The engine is consuming oil	Worn valve guides. Worn cylinder. Leaking oil seals. Too much oil in the crankcase. Worn piston rings.
The engine oil level is rising	Excessive piston clearance. Defective injection system.
The engine is losing oil	Blocked breather pipe. Defective injection system.
The engine overheats	Too little piston clearance. Cooling fins are clogged. Injection timing is incorrect. The injector is defective. The engine is overloaded.
The engine stalls	Incorrect fuel. Cold engine. Air intake is clogged. Getting false air through the injection pump. Defective injection system.
Bad acceleration	Incorrect fuel. Getting false air through the injection pump.

12. TECHNICAL DATA / SPECIFICATIONS



12.1 - TECHNICAL SPECIFICATIONS

Width: min/max	160/260 cm
Length:	345 cm
Height:	114 cm
Empty weight:	2000 kg
Materiale hopper size:	1m3 Asphalt
Fuel tank:	35L
Hydraulic tank:	70L
Engine:	Kubota V1505-E4, vertical, water-cooled, 4-stroke diesel engine, 17.7 kW / 2300 rpm.
Steering system:	Servo
Engine oil:	API-CD 10W-30
Hydraulic oil:	Type 46
Coolant:	SAE J 1034 or SAE J1814c
Fuel:	Diesel

12.2 - NOISE LEVEL

The machine's noise level exceeds the allowable general workplace noise level of 80 dB. It is therefore required that the operator wear hearing protection while using the machine.

People working nearby during the machine's operation should also wear hearing protection.

The machine is equipped with an original muffler from the manufacturer to reduce airborne noise emissions. The machine's noise level is listed according to the manufacturer's technical information.

Engine RPM (Revolutions per min)	Loaded dB	Unloaded dB
1500 r/min	81,5	80,0
1800 r/min	84	82,5
2000 r/min	85,5	83
2500 r/min	89,5	84,2
3000 r/min	92,8	91,2

13. HYDRAULIC DIAGRAM

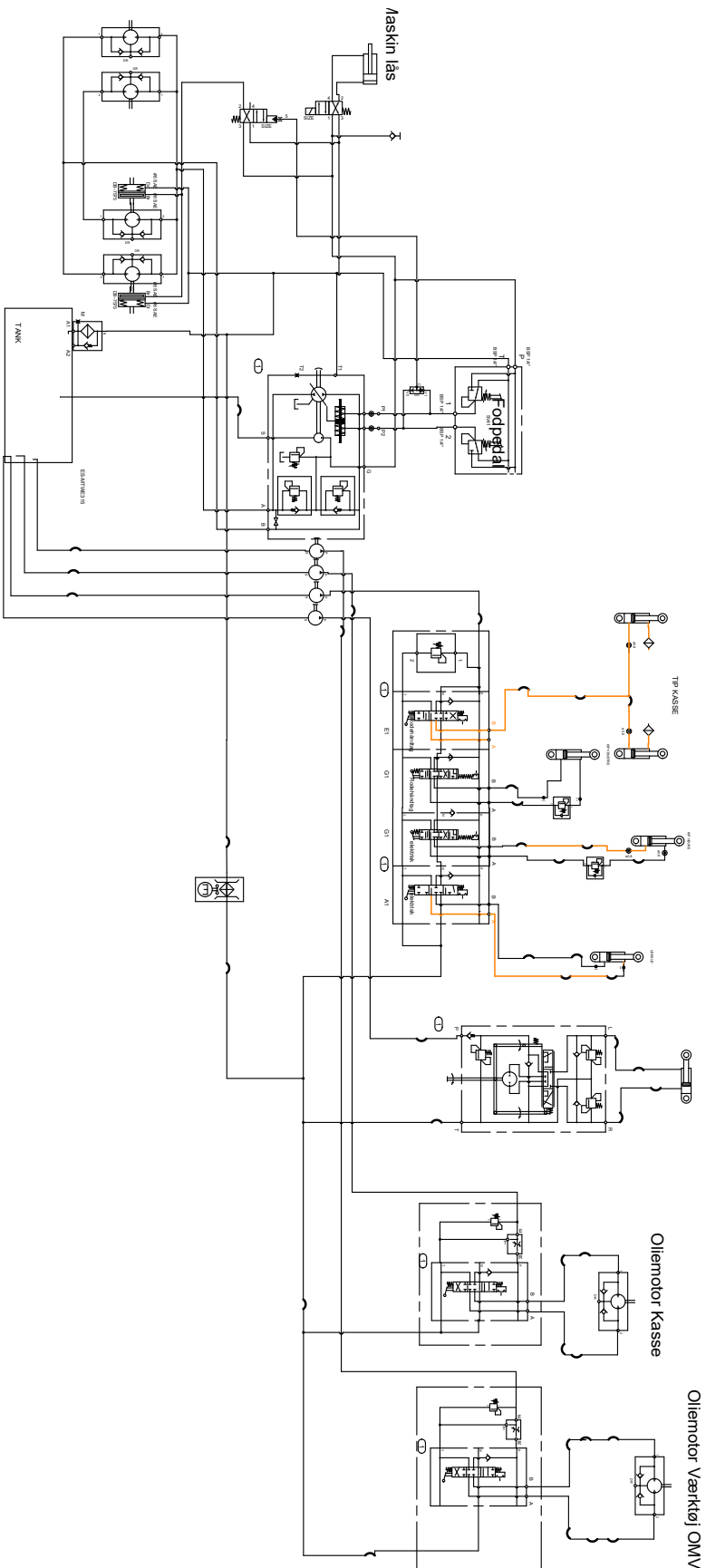

Customer : Techsolution		This document is confidential and may not be copied nor disclosed to a third party without written consent.	
Date : 19-08-2025	Drawn by : Jacob		
Date :	Checked by :		
Material :	Weight :		
Paper Size : A4	Page : 1	Status	Project number
Scale :	Pages : 1		Techsolution
			Drawing Number



14. ELECTRICAL DIAGRAM

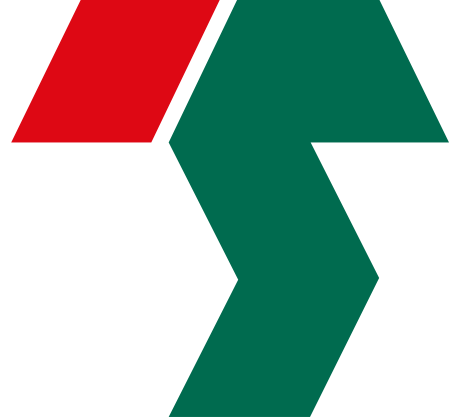

LEGENDA

1	BATTERIA / BATTERY
2	MOTORINO AVVAMENTO / STARTER MOTOR
3	ALTERNATORE / ALTERNATOR
4	OPZIONALE / LOAD / PRIMEPUMP
5	CANDELETTE / GLOW PLUG
6	SPIA OLIO / OIL SWITCH
7	O.P. / OPTIONAL / LOW FUEL SENSOR
8	SPIA ACQUA / WATER SWITCH
9	ARRESTO MOTORE / SOLENOID TO STOP
10	QUADRO AVVAMENTO / STARTER SWITCH
11	CONTORE / HOURMETER
12	SPIA ALTERNATORE / GENERATOR LAMP
13	SPIA OLIO MOTORE / ENGINE OIL LAMP
14	SPIA OPZIONALE / OPTIONAL LAMP / PREHEATING LAMP
15	SPIA CANDELETTE / PREHEATING LAMP / LOW FUEL LAMP
16	CENTRALINA CANDELETTE / LAMP TIMER
17	CENTRAL GREASE PUMP
18	STRUMENTO TEMP. ACQUA / WATER TEMPERATURE INDICATOR
19	RELE ARRESTO / SOLENOID TO STOP RELAY
20	TERMISTORE ACQUA MOTORE / WATER TEMPERATURE SENDER

COLORI FILI WIRE COLOURS

A	AZZURRO
B	BIANCO
C	ARANCIONE
G	GIALLO
H	GRIGIO
L	BLU
M	MARRONE
N	NERO
R	ROSSO
S	ROSA
V	VERDE
Z	VIOLA

NOTE:
LA COLORAZIONE DEI FILI BICOLORI
VIENE INDICATA CON LA COMPOSIZIONE
DELLE SIGLE SOPRA ELENCAATE,ESEMPLO:
G/V GIALLO / VERDE
(COLORAZ. TRASVERSALE)
G-V GIALLO / VERDE
(COLORAZ. LONGITUDINALE)

A	CELESTIAL BLU
B	WHITE
C	ORANGE
G	YELLOW
H	GREY
L	BLUE
M	BROWN
N	BLACK
R	RED
S	PINK
V	GREEN
Z	VIOLET

NOTES:
1. ABOVE COLOURS COULD BE USED EITHER
ALONE OR COMBINED TO OBTAIN DIFFERENT
SOLUTIONS.
2. IN CASE OF COLOURS COMBINATION THE
FOLLOWING METHODS AND REF. ARE APPLIED:
- WIRE WITH HORIZONTAL STRIPS (I.E. G-V)
- WIRE WITH TRANSVERSE STRIPS (I.E. G/V)

PCSCHEMATIC Automation

Proiekttitel:	Marvel TS100	Sagsnr.:		Proiektrev.:		Side	8
Kunde:	Tech Solution	DCC:				Målestok:	1:1
Sidettitel:	Motor panel	Tegningsnr.:		Siderov.:		Formge side:	7
Filnavn:	052-TechSolution-Marvel TS100-Diff-Ver4	Konstr. (projektside):	bn / bh	Sidst udskrevet:	26-02-2026	Næste side:	9
Sideret.:		Godk. (dato/må):		Sidst rettet:	25-02-2026	Antal sider ialt:	12



Part of Granby Diesel

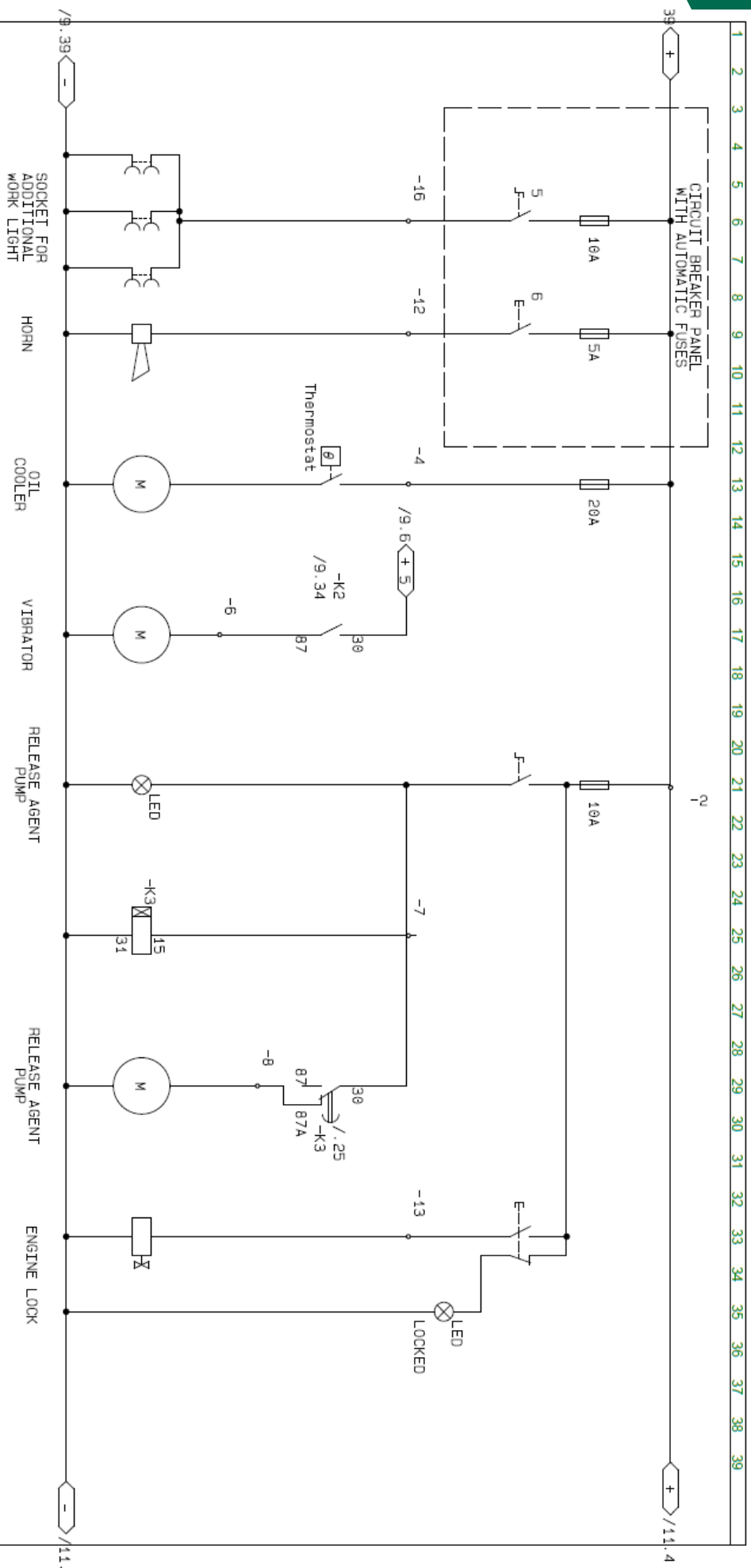
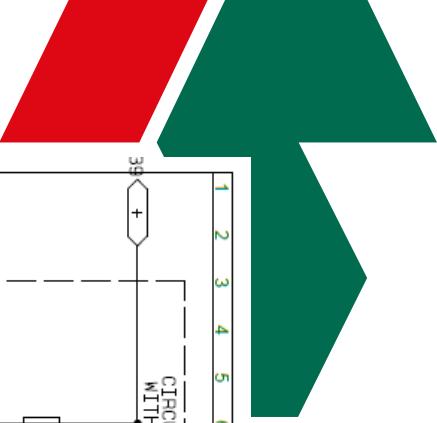

Projekttitel: Marvel TS100		Sagsnr.:		Projektnr.:		PCSCHEMATIC Automation	
Kunde: Tech Solution		DCC:		Målestok:		1:1	
Sidetitel: Breaker Panel		Tegningsnr.:		Siderov.:		9	
Filnavn: 052-TechSolution-Marvel TS100-Diff-Ver4		Konstr. (projektside): bh / bh		Sidst udskrevet: 26-02-2026		Næste side: 11	
Sideraf.:		Godk. (dato/nr.):		Sidst rettet: 26-02-2026		Antal sider ialt: 12	



1 2 3 4 5 6 7 8 9 10 11 12 13 14 15 16 17 18 19 20 21 22 23 24 25 26 27 28 29 30 31 32 33 34 35 36 37 38 39

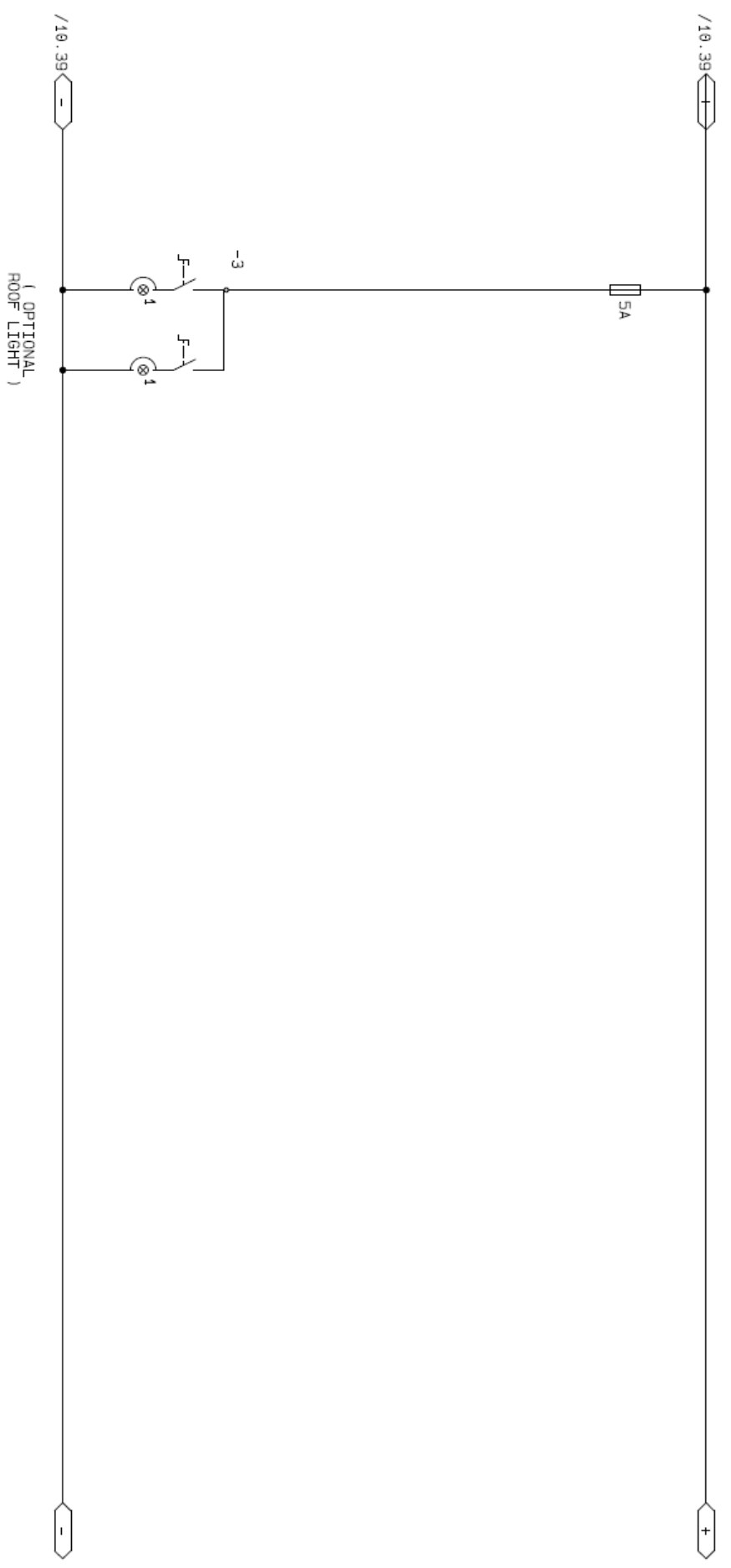

Projekttittel: Marvel TS100		Sagsnr.:		Projektnr.:		Side	
Kunde: Tech Solution		DCC:		Siderov.:		Målestok:	
Sidetittel: Roof light		Tegningsnr.:		Sidst udskrevet:		Forrige side:	
Flisavn: 052-TechSolution-Marvel TS100-Diff-Ver4		Konstr. (projektside): bh / bh		Sidst udskrevet: 26-02-2026		Næste side:	
Sideraf.:		Godk. (dato/int):		Sidst rettet: 25-02-2026		Antal sider/alt:	
				PCSCHEMATIC Automation			
						11	
						1:1	
						10	
						12	
						12	



15. WARRANTY TERMS

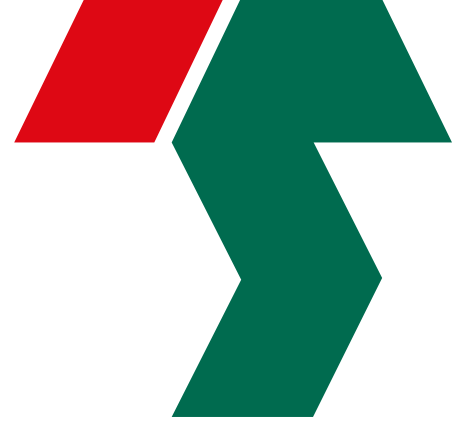

Warranty period:

The manufacturer of this machine provides a warranty for 12 months (max. 1000 operating hours). The warranty period begins on the delivery date.

The warranty covers:

Components that need to be replaced or repaired due to material or manufacturing defects.

The manufacturer's warranty is void if:

- The machine is used improperly.
- The machine is used without following the instruction manual and safety regulations.
- The service maintenance schedule is exceeded, or foreign parts are used, such as filters.
- The machine is used after a fault has been detected, resulting in a more expensive repair than the original fault.

The owner's own insurance should cover:

- Fire, burglary, theft, and vandalism.
- Water and frost damage.
- Corrosion damage caused by battery acid.
- Damage caused by wind and weather. The manufacturer's warranty does not apply in these cases.

Approval of compensation claims:

Requires that the defective part is shown to the manufacturer or its representative within 2 weeks after the damage occurs. Ownership of the damaged part(s) is transferred to the supplier of the new parts.

The warranty only covers components, not:

- Shipping costs
- Costs for waiting time, the machine owner's labor time, and travel expenses.
- Loss of operation and other subsequent costs.

Other:

Before a warranty repair, the manufacturer must be contacted to agree on the procedure. Once the repair has been initiated or completed, it is too late to claim warranty. These warranty terms can only be changed through a separate agreement.

16. ADDITIONAL EQUIPMENT

The model may be supplied with the following additional equipment:

16.1 - GAS BOTTLE HOLDER

DANGER

After using a burner on tools and other areas, there may be a risk of burns and fire. Therefore, make sure that the heated material has cooled down before touching it.



16.2 - CURB TOOLS

DANGER

When installing and removing, the machine must be stopped, the engine turned off, and the machine in position P.



16.3 - LUBRICANT TANK

DANGER

When installing and removing, the machine must be stopped, the engine switched off, and the machine in position P.

REMEMBER GLOVES AND GOGGLES - NOTE: CONTACT A DOCTOR IN CASE OF ACCIDENTS IN THE EYE AREA.



16. ADDITIONAL EQUIPMENT

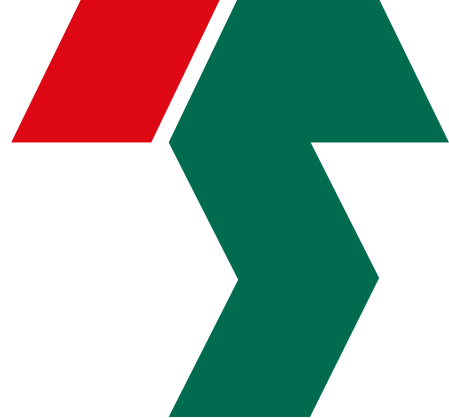

16.4 - SHOVLÉ BRACKET 1 - 2

DANGER

When installing and removing, the machine must be stopped, the engine turned off, and the machine in position P.



16.5 - GUIDE PEN

DANGER

When installing and removing, the machine must be stopped, the engine turned off, and the machine in position P.



16.6 - FOUR-WHEEL DRIVE

DANGER

When installing and removing, the machine must be stopped, the engine switched off, and the machine in position P.



16. ADDITIONAL EQUIPMENT

16.7 - CRUISE CONTROL

DANGER

When installing and removing, the machine must be stopped, the engine turned off, and the machine in position P.



16.8 - ADDITIONAL WORK LIGHTS

DANGER

When mounting and dismounting, the machine must be stopped, the engine shut down and the machine in position P.



Central lubrication - SB5

Electric grease pump. Cartridge tank
Original instructions

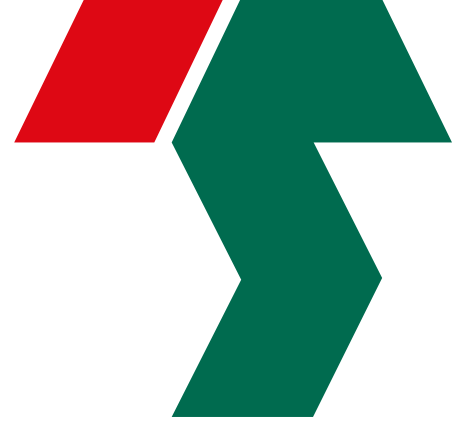

SB - 5

45.12-24DC.CT

The pump is supplied complete with electronic board - power supply and M12x1 connector for progressive sensor. The pump outlet is 1/8 "BSP and is complete with an adjustable maximum pressure valve. The factory setting is 250 bar.

45.12-24DC.PG.CT

The pump is supplied complete with electronic board - power supply and M12x1 connector for progressive sensor, pressure gauge (0-400 bar). The pump outlet is 1/8 "BSP and is complete with an adjustable maximum pressure valve. The factory setting is 250 bar.



POSITION	PART NO	DESCRIPTION
1	A70.0931030	SB-5 motor box assembly + protection
2	A91.111676	SB-5 circuit board w/timer
3	A70.0931032	SB-5 motor cover assembly

SB - 5

4. Control unit functions

4.1 - POWER UP

When the pump is powered up, the display (D1 and D2) blinks five times showing C and 0. Then the pump starts with the saved program: a working cycle (green led lit) or a pause cycle (green led blinking).

4.2 - OPERATING MODE

In operating mode, the board controls the pump by alternating working cycles and pause cycles. The pump can be set to work with pause time/working time, pause time/working cycles, pause time and working time controlled by inductive sensor installed on a progressive divider.

4.3 - ELECTRONIC TIMER

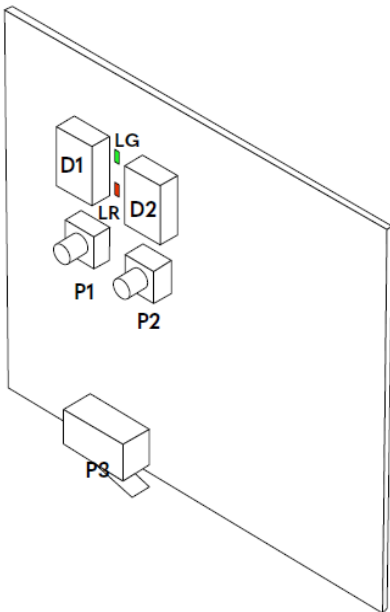

DISPLAY	FUNCTION	
D1	Show current program	
D2	Shows current program values	
KEY	FUNCTION	
P1+P2	Access timer settings / confirm settings	
D1	Cycles Display D1 functions	
D2	Cycles Display D2 functions	
P3	Immediately starts an extra duty cycle for the set time Resets all alarms	
LED	STATUS	SIGNAL
Red	Fixed	Alarm signal
Green	Fixed	Working cycle
Green	Blinking	Pause cycle

4.4 - ACCESSING THE ELECTRONIC TIMER

To access the timer functions, gently screw the porthole placed on the front panel of the pump body then remove it.

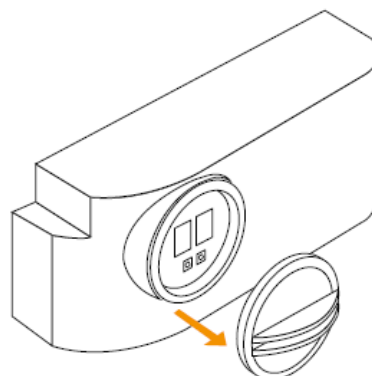
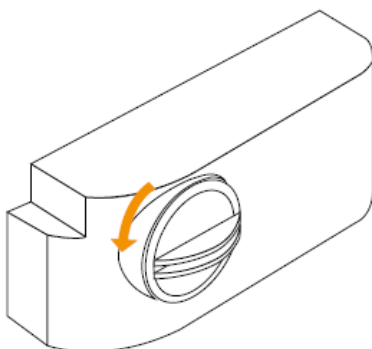

SB - 5

4.5 - Programming mode

When the pump is powered up, **D1** and **D2** show the current program.

Click once **P1+P2** simultaneously to enter the programming mode.

Blinking lines appear for five seconds **C0** appears. The timer is now in programming mode

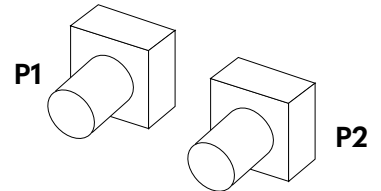
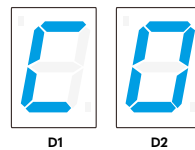
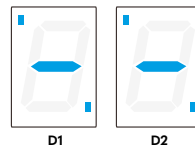
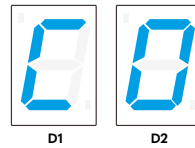

4.6 - Cycling Modes (P1-D1)

Start from programming mode. **D1** shows **C** and **D2** show **0**.

Click once **P1**, **D1** will cycle up on the next menu, **0**.

Clicking again **P1**, **D1** will cycle up through all the menus (**P, A, L, S, U**)

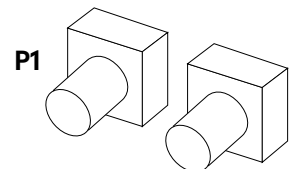
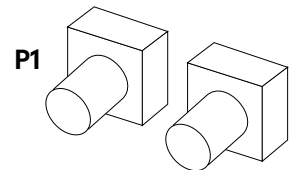
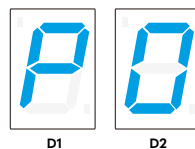
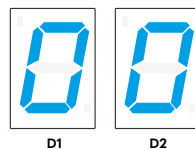
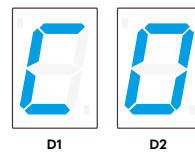

4.7 - Cycling values (P2-D2)

Start the programming mode **D1** shows **C** and **D2** shows **0**

Click once **P2**, **D2** will cycle up increasing value from **0** to **1**.

Clicking again **P2**, **D2** will cycle up through all the values (depending on the mode, see next page).

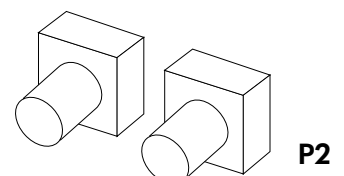
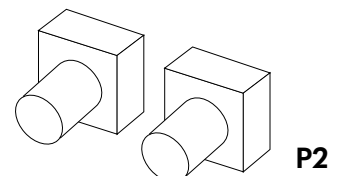
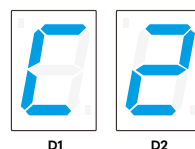
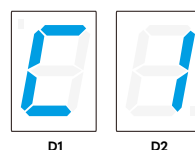
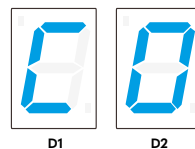

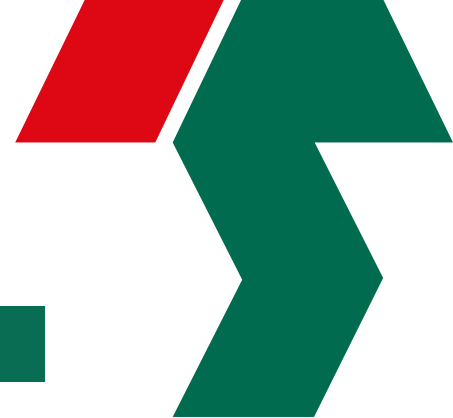

4.8 - Electronic timer function and values

C	Control Type	0: To adjust working (O) and pause (P) time	1: To adjust pause (P) time and Number of Cycles (I)	2: Pause and work time controlled by inductive sensor on progressive divider
		0: 30 seconds.	1: 1 cycles.	0: 30 seconds.
		1: 60 seconds.	2: 2 cycles.	1: 60 seconds.
		2: 120 seconds.	3: 3 cycles.	2: 120 seconds.
		3: 180 seconds.	4: 4 cycles.	3: 180 seconds.
O	Work time.	4: 240 seconds.	5: 5 cycles.	4: 240 seconds.
		5: 300 seconds.	6: 6 cycles.	5: 300 seconds.
		6: 360 seconds.	7: 7 cycles.	6: 360 seconds.
		7: 420 seconds.	8: 8 cycles.	7: 420 seconds.
		8: 480 seconds.	9: 9 cycles.	8: 480 seconds.
		9: 540 seconds.		9: 540 seconds.
		0: 30 minute.	0: 30 minute.	0: 30 minute.
		1: 60 minute.	1: 60 minute.	1: 60 minute.
		2: 120 minute.	2: 120 minute.	2: 120 minute.
		3: 180 minute.	3: 180 minute.	3: 180 minute.
P	Pause time.	4: 240 minute.	4: 240 minute.	4: 240 minute.
		5: 300 minute.	5: 300 minute.	5: 300 minute.
		6: 360 minute.	6: 360 minute.	6: 360 minute.
		7: 420 minute.	7: 420 minute.	7: 420 minute.
		8: 480 minute.	8: 480 minute.	8: 480 minute.
		9: 540 minute.	9: 540 minute:	9: 540 minute.



SB - 5

4.8 - Electronic timer function and values

A: Time to check the work cycles.
(If the inductive sensor does not send the signal within this time, we will receive an alarm).

1:	2,5 Minutes
2:	5 Minutes (Standard)
3:	7,5 Minutes
4:	10 Minutes
5:	12,5 Minutes
6:	15 Minutes
7:	17,5 Minutes
8:	20 Minutes
9:	25 Minutes

L: Low Alarm

O: No low level control (standard).

1: Yes, low level control.

S: Cartridge size

O: 400 g.

1: 500 g.

U: Pre-treatment

O: No, Pre-treatment

1: Yes, Pre-treatment

SB - 5



5. Fault control

Motor fault.
Press P3 to reset the alarm.

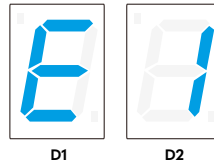

Supply overvoltage fault.
Press P3 to reset the alarm.

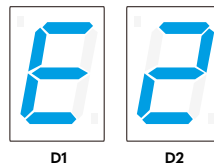

Supply undervoltage fault.
Press P3 to reset the alarm.

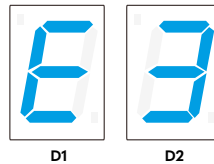

Motor output overcurrent.
Press P3 to reset the alarm.

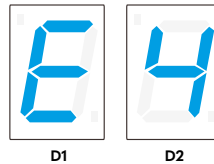

Alarm cycle C = 1.
Press P3 to reset the alarm.

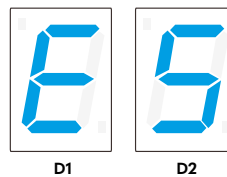

Alarm cycle C = 2.
Press P3 to reset the alarm.

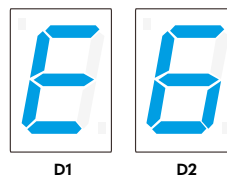

Low level alarm.
Press P3 to reset the alarm.

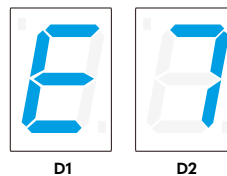



SB - 5

6 Grease level control, Pre-treatment, extra cycle

6.1 Grease level control (L)

When grease level monitoring is activated (**L=1**), the timer sums the SECONDS for motor activation based on the cartridge size specified in parameter S. When grease level monitoring is active, two dots will appear on displays **D1** and **D2** when the motor is running.

The board will signal a warning level by lighting the red **LED LR**, and the display will show **LO** when this sum reaches the value of seconds set according to the cartridge size specified in parameter **S**.

The warning indication for the level can be reset by performing a counter reset by holding down the **P3** button until the display shows **LL**.

In the event of an unexpected cartridge replacement, the counter can be reset at any time by pressing the **P3** button for at least 5 seconds until the **LL** indication appears.

6.2 Pre-treatment

If the pre-treatment function is turned off (**parameter U=0**), the system can control the shutdown of the board during its operation, whether it is a motor work cycle or a pause.

The next time it is turned on, the system will restart exactly where it left off, i.e., by completing the remaining pause period or with the motor work phase.

If pre-treatment is enabled (**U=1**), a lubrication phase will always be performed when the board is turned on again, and then it will enter the pause phase.

6.3 Extra cycle

There is an **extra cycle function** that can be activated by pressing the **P3** button for 1 second or by a pulse to the external release input. When the function is activated, the board will start a full lubrication phase according to the edited program.

SB - 5

7. Electrical connections

The electrical connection is the user's responsibility, who must identify the power connection, minimum level alarm, and/or cycle alarm.

Connect the machine to the electrical line as indicated on the pump near the connection. The power cable must have a cross-sectional area suitable for the machine's power consumption and be of a type that complies with applicable regulations.

Both electrical connections are located on the underside of the pump

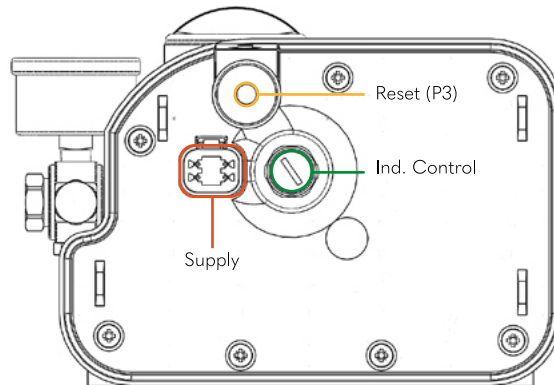

7.1 Power supply connection

The SB-5 pump is supplied complete with a four-pin electrical Deutsch connector, which provides power to the pump and handles any alarm and level signals. Upon request, it is possible to order the connection complete with a four-wire cable (1 mm²) in two different lengths (5, 10 meters).

PART N°	CABLE
45.CDL.4.05	5 M.
45.CDL.4.10	10 M.

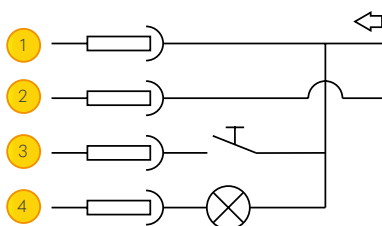

IN 12 V or 24 V DC (+) GND
reference potential (-)
Lubrication / release
external lamp (max. 200mA)

SB - 5

7.2 Cable with inductive control

An additional connection for handling inductive control can be installed on the pump. The connection complete with cable can be ordered upon request.

M12X1 (M) / M8X1 (F)	M12X1 (M) / M12X1 (F)	CABLE
45.CDC.3.05	45.CDC.4.05	5 M.
45.CDC.3.10	45.CDC.4.10	10 M.

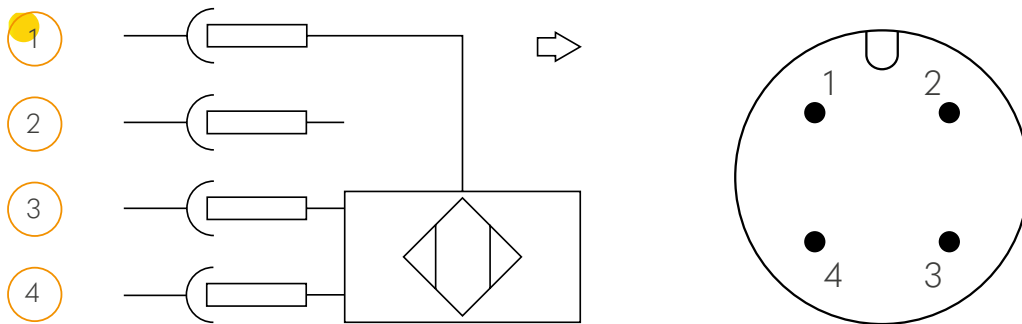

SB - 5

8. Screwing in or replacing the cartridge.

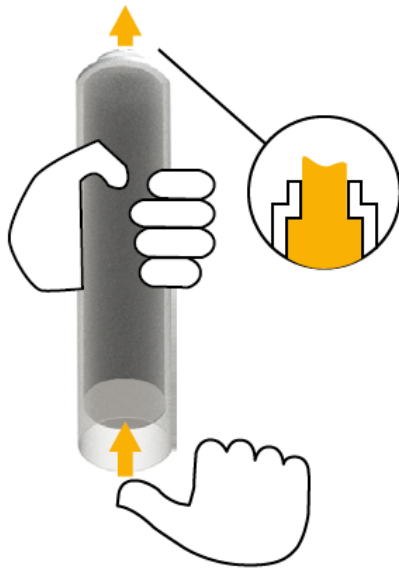

To avoid air pockets, press the piston on the cartridge gently upward until the lubricant starts to flow out, before inserting it into the unit.

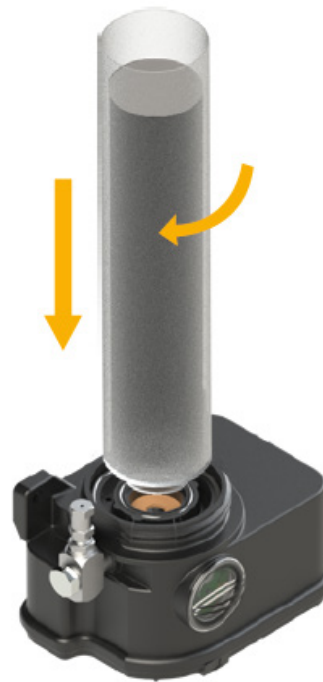

Then screw the cartridge into the unit.

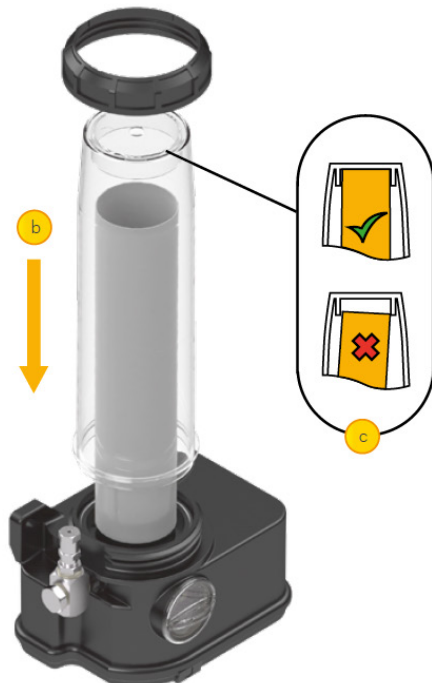

Place the cartridge protection (b) on, and ensure that the cartridge fits correctly in the guide on the cartridge protection (c).



Tighten the nut (a).

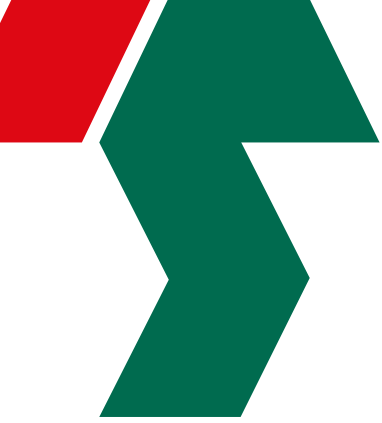

17. SERVICE

Servicebook - Visit 1.

Service type: _____

Machine number: _____

Operating hours: _____

Service description/comment: _____

Date: _____

Customer signature: _____ Technician signature: _____

Servicebook - Visit 2.

Service type: _____

Machine number: _____

Operating hours: _____

Service description/comment: _____

Date: _____

Customer signature: _____ Technician signature: _____

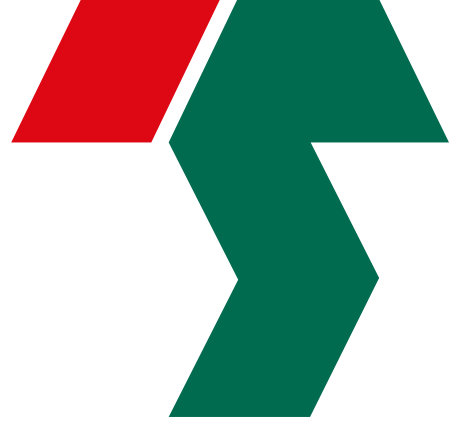

Servicebook - Visit 3.

Service type: _____

Machine number: _____

Operating hours: _____

Service description/comment: _____

Date: _____

Customer signature: _____ Technician signature: _____

Servicebook - Visit 4.

Service type: _____

Machine number: _____

Operating hours: _____

Service description/comment: _____

Date: _____

Customer signature: _____ Technician signature: _____

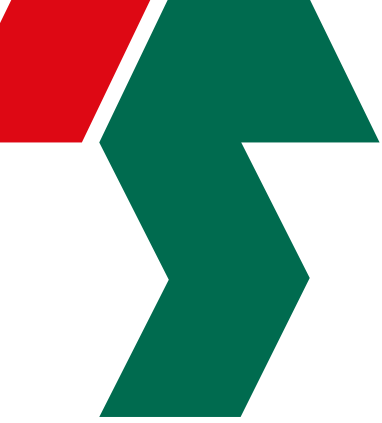

Servicebook - Visit 5.

Service type: _____

Machine number: _____

Operating hours: _____

Service description/comment: _____

Date: _____

Customer signature: _____ Technician signature: _____

Servicebook - Visit 6.

Service type: _____

Machine number: _____

Operating hours: _____

Service description/comment: _____

Date: _____

Customer signature: _____ Technician signature: _____

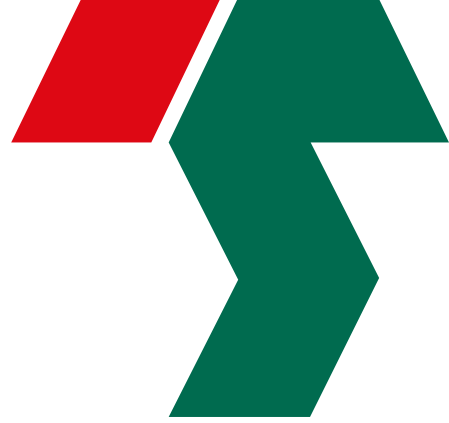

Servicebook - Visit 7.

Service type: _____

Machine number: _____

Operating hours: _____

Service description/comment: _____

Date: _____

Customer signature: _____ Technician signature: _____

Servicebook - Visit 8.

Service type: _____

Machine number: _____

Operating hours: _____

Service description/comment: _____

Date: _____

Customer signature: _____ Technician signature: _____

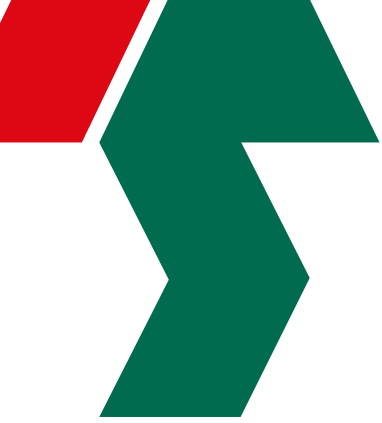

Servicebook - Visit 9.

Service type: _____

Machine number: _____

Operating hours: _____

Service description/comment: _____

Date: _____

Customer signature: _____ Technician signature: _____

Servicebook - Visit 10.

Service type: _____

Machine number: _____

Operating hours: _____

Service description/comment: _____

Date: _____

Customer signature: _____ Technician signature: _____

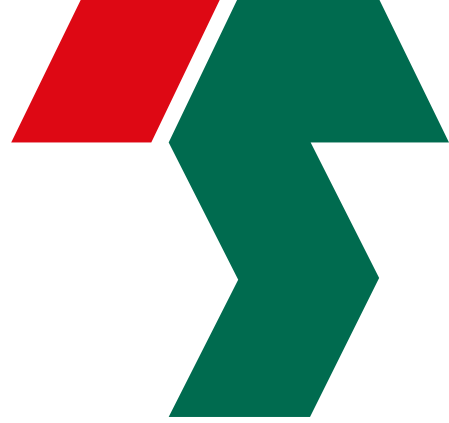

Servicebook - Visit 11.

Service type: _____

Machine number: _____

Operating hours: _____

Service description/comment: _____

Date: _____

Customer signature: _____ Technician signature: _____

Servicebook - Visit 12.

Service type: _____

Machine number: _____

Operating hours: _____

Service description/comment: _____

Date: _____

Customer signature: _____ Technician signature: _____

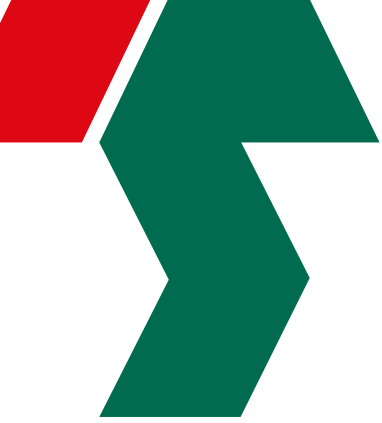

Servicebook - Visit 13.

Service type: _____

Machine number: _____

Operating hours: _____

Service description/comment: _____

Date: _____

Customer signature: _____ Technician signature: _____

Servicebook - Visit 14.

Service type: _____

Machine number: _____

Operating hours: _____

Service description/comment: _____

Date: _____

Customer signature: _____ Technician signature: _____



Tech-Solution

Part of **Granly Diesel**

